

Doorpac fact sheet 6

Glazing of 30 minute Fire Doors (FD 30)

Manufacturers & Suppliers of Internal Doorsets,
Glazed Apertures & Screens and Joinery Products

Including:

- Fire doors
- Glazed apertures
- Fire glass
- Beads and fixings
- Specialist information

Many timber doors include glazed apertures, either as a design feature or in order to comply with Building Regulations. However, when the door is a fire door, all the elements of the glazed aperture must, when used together, be capable of withstanding the fire. They must not reduce the overall effectiveness of the door in holding back a fire.

This fact card is intended to provide some basic essential information on the correct way to specify and use glazed apertures in 30-minute fire doors (FD 30). It tells you what to look for and how to ensure that you are using the correct life-protecting materials.

Fire Doors

Most fire doors manufactured in the UK are manufactured as fire door leaves. Before they are installed, many will be modified in some way, whether by the addition of a door frame, the insertion of a glazed aperture or other types of apertures, or, ideally, conversion into a complete fire doorset or assembly. Glazed apertures provide added safety in everyday use. In the event of a fire, they aid detection of fire and smoke, whilst providing visibility to potential escape routes. The size and positioning of apertures is very important, as this will ultimately have a bearing upon the behaviour of the fire door assembly in the event of a fire.

Cutting apertures for glazing and other apertures in a fire door on site IS NOT permitted (even by an approved aperture cutter), under the BWF-CERTIFIRE Fire Door and Doorset Scheme. Glazing pre-cut apertures in fire doors on site is permitted, but MUST be undertaken by a trained and competent installer in accordance with the instructions provided by the door manufacturer. The BWF recommends that fire doors should only be glazed by certificated members of the BWF-CERTIFIRE scheme or by FIRAS registered installers in order to maintain the door's full certification.



Doorpac fact sheet 6

Fire door seals



CAF 000 A123456
Company Name
Tel 01939 907654

This Certified Glazed Aperture has been produced in accordance with the rules and manufacturer's instructions, conforms to the fire door rating shown on their accompanying BWF-CERTIFIRE label.

CERTIFIED GLAZED APERTURE
bwf.org.uk

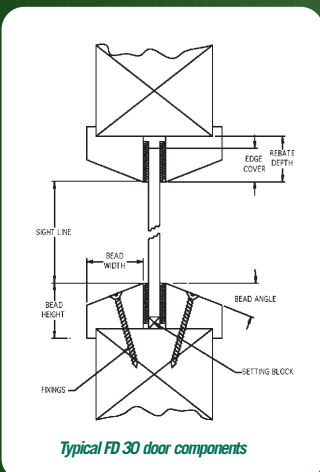

Key Elements (see also section detail):

The following elements are essential for the success of any properly installed glazed aperture in a 30-minute (FD 30) fire door assembly.

Glazed Apertures: only certain door types are designed to perform with glazed apertures. Make sure that any aperture has been properly formed, either by the original door manufacturer, or by one of his approved "aperture formers". If the aperture is cut in an unsuitable door type, or by someone who does not recognise the correct procedure and materials, the whole fire resistant property of the door leaf may be destroyed. Depending on the door's construction, an aperture liner of wood or intumescent material may be needed.

- Aperture size
- No of apertures
- Location of apertures
- Type of apertures
- Glazing systems

In every case, the door manufacturer must be able to supply evidence that he holds test certification for the specific door design.

If this cannot be provided, there is no proof that the installation would work in a fire, and the inspecting authority may refuse to accept it.

Fire glass: a specialist fire glass must be used. There are four quite separate types of fire glass, each of which performs in its own individual way. Never assume that a system which has been tested or certificated for one specific glass may be suitable for a different glass, unless the manufacturer can provide his own test evidence or certification.

The fire glass types are:

- Imbedded wired glass
- Special glass composition – borosilicate, ceramic etc.
- Specially tempered/toughened glass (this needs precisely detailed edge cover and clearances)
- Laminated glass with reactive fire resisting interlayer(s)

The door manufacturer should specify:

- Type of glass
- Thickness
- Aspect ratio
- Maximum dimensions of glass
- Special glazing requirements, especially edge cover/clearances, setting block types
- Suitability for door type

As with apertures, the door manufacturer must be able to supply test evidence to support the specification.

Beads and Fixings: the beads and their fixing are absolutely vital in retaining the fire glass in place for the whole of the required time period.

Attention must be paid especially to:

- Bead material: If timber beads are used, it is particularly important to use the correct species
- Bead size and shape: There must be enough material to char throughout the whole fire test (although angled beads are shown in the diagram, some glass types will permit the use of flat timber beads)
- Frequency, size and type of bead fixings: screws, pins or brads
- Angle of fixing: see diagram
- Glass edge cover and clearances

Glazing seals: Whatever glazing medium is used, it must hold test certification for the particular panel size and application within the door design and be appropriate and compatible with the chosen glass type.

The seals between the glass and beads on each side may take the form of:

- Pre-formed rigid or flexible strips
- Pre-formed channels to wrap around the edge of the glass
- Gun-able mastic compounds

The BWF-CERTIFIRE Fire Door & Doorset Scheme Directory provides a complete list of fully certificated manufacturers and suppliers. Details can be found on the BWF website at www.bwf.org.uk For more detailed information on a specific door or glazing, please contact the door manufacturer or glass manufacturer, who will hold full details of test certification. The use of vision panels in 60-minute timber fire doors (FD 60) is a completely separate (and much more complex) subject. It requires different glass types, glazing methods and bead sizes. Contact the door manufacturers or glass manufacturers who offer FD 60 products for specific details. More detailed information about fire-resistant glazing can be found in the "Fire Glazing – Best Practice Guide" produced by the Glass and Glazing Federation. Contact the GGF at www.ggf.org.uk